

SESSION - 1

Q. 1 – Q. 5 carry one mark each.

- Q.1 John Thomas, an _____ writer, passed away in 2018.
- (A) imminent (B) prominent
(C) eminent (D) dominant
- Q.2 _____ I permitted him to leave, I wouldn't have had any problem with him being absent, _____ I?
- (A) Had, wouldn't (B) Have, would
(C) Had, would (D) Have, wouldn't
- Q.3 A worker noticed that the hour hand on the factory clock had moved by 225 degrees during her stay at the factory. For how long did she stay in the factory?
- (A) 3.75 hours (B) 4 hours and 15 mins
(C) 8.5 hours (D) 7.5 hours
- Q.4 The sum and product of two integers are 26 and 165 respectively. The difference between these two integers is _____.
- (A) 2 (B) 3 (C) 4 (D) 6
- Q.5 The minister avoided any mention of the issue of women's reservation in the private sector. He was accused of _____ the issue.
- (A) collaring (B) skirting
(C) tying (D) belting

Q. 6 – Q. 10 carry two marks each.

- Q.6 Under a certain legal system, prisoners are allowed to make one statement. If their statement turns out to be true then they are hanged. If the statement turns out to be false then they are shot. One prisoner made a statement and the judge had no option but to set him free. Which one of the following could be that statement?
- (A) I did not commit the crime
(B) I committed the crime
(C) I will be shot
(D) You committed the crime

Q.7 A person divided an amount of Rs. 100,000 into two parts and invested in two different schemes. In one he got 10% profit and in the other he got 12%. If the profit percentages are interchanged with these investments he would have got Rs.120 less. Find the ratio between his investments in the two schemes.

- (A) 9 : 16 (B) 11 : 14 (C) 37 : 63 (D) 47 : 53

Q.8 Congo was named by Europeans. Congo's dictator Mobuto later changed the name of the country and the river to Zaire with the objective of Africanising names of persons and spaces. However, the name Zaire was a Portuguese alteration of *Nzadi o Nzere*, a local African term meaning 'River that swallows Rivers'. Zaire was the Portuguese name for the Congo river in the 16th and 17th centuries.

Which one of the following statements can be inferred from the paragraph above?

- (A) Mobuto was not entirely successful in Africanising the name of his country
(B) The term *Nzadi o Nzere* was of Portuguese origin
(C) Mobuto's desire to Africanise names was prevented by the Portuguese
(D) As a dictator Mobuto ordered the Portuguese to alter the name of the river to Zaire

GATE 2019 General Aptitude (GA) Set-2

- Q.9 A firm hires employees at five different skill levels P, Q, R, S, T. The shares of employment at these skill levels of total employment in 2010 is given in the pie chart as shown. There were a total of 600 employees in 2010 and the total employment increased by 15% from 2010 to 2016. The total employment at skill levels P, Q and R remained unchanged during this period. If the employment at skill level S increased by 40% from 2010 to 2016, how many employees were there at skill level T in 2016?

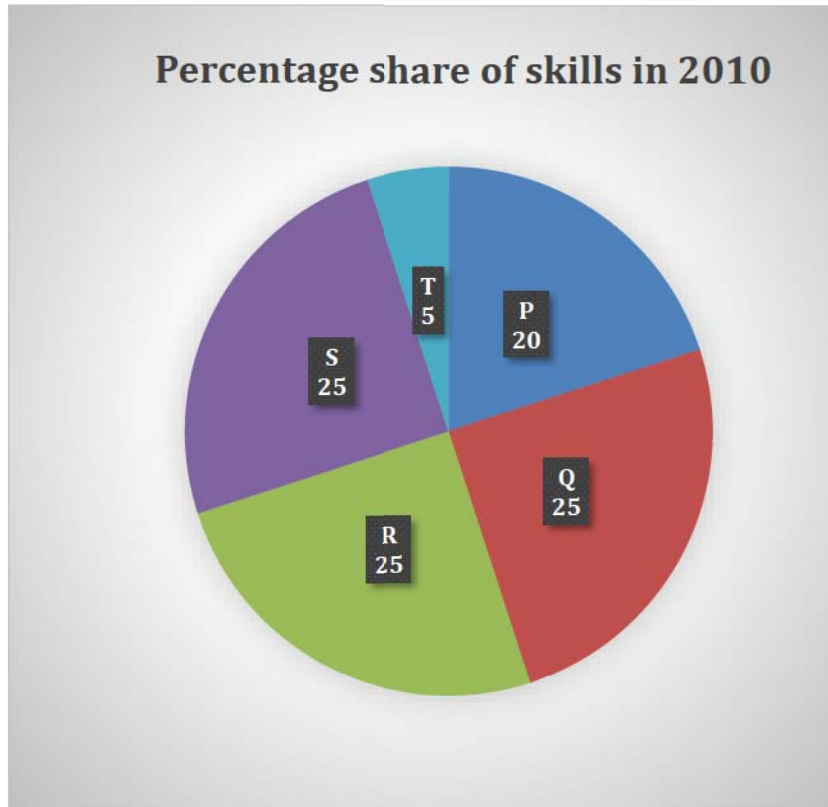

- (A) 30 (B) 35 (C) 60 (D) 72
- Q.10 M and N had four children P, Q, R and S. Of them, only P and R were married. They had children X and Y respectively. If Y is a legitimate child of W, which one of the following statements is necessarily FALSE?
- (A) M is the grandmother of Y
(B) R is the father of Y
(C) W is the wife of R
(D) W is the wife of P

END OF THE QUESTION PAPER

Q. 1 – Q. 25 carry one mark each.

Q.1 Consider the matrix

$$P = \begin{bmatrix} 1 & 1 & 0 \\ 0 & 1 & 1 \\ 0 & 0 & 1 \end{bmatrix}$$

The number of distinct eigenvalues of P is

- (A) 0 (B) 1 (C) 2 (D) 3

Q.2 A parabola $x = y^2$ with $0 \leq x \leq 1$ is shown in the figure. The volume of the solid of rotation obtained by rotating the shaded area by 360° around the x -axis is

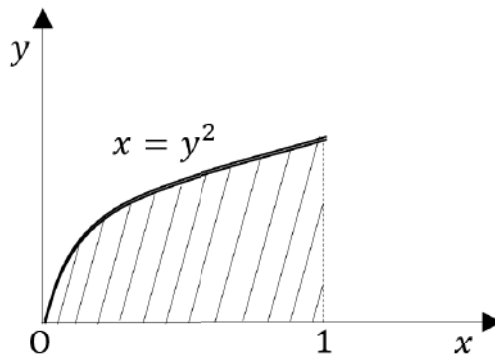

- (A) $\frac{\pi}{4}$ (B) $\frac{\pi}{2}$
 (C) π (D) 2π

Q.3 For the equation $\frac{dy}{dx} + 7x^2y = 0$, if $y(0) = 3/7$, then the value of $y(1)$ is

- (A) $\frac{7}{3}e^{-7/3}$ (B) $\frac{7}{3}e^{-3/7}$
 (C) $\frac{3}{7}e^{-7/3}$ (D) $\frac{3}{7}e^{-3/7}$

Q.4 The lengths of a large stock of titanium rods follow a normal distribution with a mean (μ) of 440 mm and a standard deviation (σ) of 1 mm. What is the percentage of rods whose lengths lie between 438 mm and 441 mm?

- (A) 81.85% (B) 68.4% (C) 99.75% (D) 86.64%

- Q.5 A flat-faced follower is driven using a circular eccentric cam rotating at a constant angular velocity ω . At time $t = 0$, the vertical position of the follower is $y(0) = 0$, and the system is in the configuration shown below.

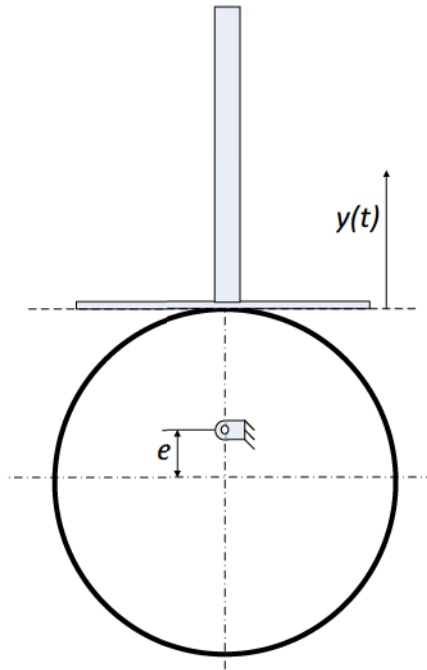

The vertical position of the follower face, $y(t)$ is given by

- (A) $e \sin \omega t$ (B) $e(1 + \cos 2\omega t)$ (C) $e(1 - \cos \omega t)$ (D) $e \sin 2\omega t$

- Q.6 The natural frequencies corresponding to the spring-mass systems I and II are ω_I and ω_{II} , respectively. The ratio $\frac{\omega_I}{\omega_{II}}$ is

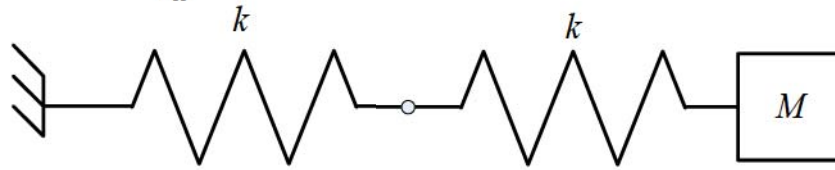

SYSTEM I

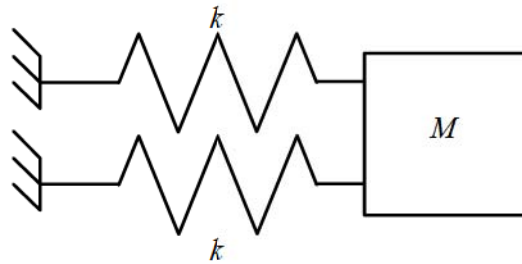

SYSTEM II

- (A) $\frac{1}{4}$ (B) $\frac{1}{2}$ (C) 2 (D) 4
- Q.7 A spur gear with 20° full depth teeth is transmitting 20 kW at 200 rad/s. The pitch circle diameter of the gear is 100 mm. The magnitude of the force applied on the gear in the radial direction is
- (A) 0.36 kN (B) 0.73 kN (C) 1.39 kN (D) 2.78 kN
- Q.8 During a non-flow thermodynamic process (1-2) executed by a perfect gas, the heat interaction is equal to the work interaction ($Q_{1-2} = W_{1-2}$) when the process is
- (A) Isentropic (B) Polytropic
(C) Isothermal (D) Adiabatic

Q.9 For a hydrodynamically and thermally fully developed laminar flow through a circular pipe of constant cross-section, the Nusselt number at constant wall heat flux (Nu_q) and that at constant wall temperature (Nu_T) are related as

(A) $Nu_q > Nu_T$

(B) $Nu_q < Nu_T$

(C) $Nu_q = Nu_T$

(D) $Nu_q = (Nu_T)^2$

Q.10 As per common design practice, the three types of hydraulic turbines, in descending order of flow rate, are

(A) Kaplan, Francis, Pelton

(B) Pelton, Francis, Kaplan

(C) Francis, Kaplan, Pelton

(D) Pelton, Kaplan, Francis

Q.11 A slender rod of length L , diameter d ($L \gg d$) and thermal conductivity k_1 is joined with another rod of identical dimensions, but of thermal conductivity k_2 , to form a composite cylindrical rod of length $2L$. The heat transfer in radial direction and contact resistance are negligible. The effective thermal conductivity of the composite rod is

(A) $k_1 + k_2$

(B) $\sqrt{k_1 k_2}$

(C) $\frac{k_1 k_2}{k_1 + k_2}$

(D) $\frac{2k_1 k_2}{k_1 + k_2}$

- Q.12 Consider an ideal vapor compression refrigeration cycle. If the throttling process is replaced by an isentropic expansion process, keeping all the other processes unchanged, which one of the following statements is true for the modified cycle?
- (A) Coefficient of performance is higher than that of the original cycle.
 - (B) Coefficient of performance is lower than that of the original cycle.
 - (C) Coefficient of performance is the same as that of the original cycle.
 - (D) Refrigerating effect is lower than that of the original cycle.
- Q.13 In a casting process, a vertical channel through which molten metal flows downward from pouring basin to runner for reaching the mold cavity is called
- (A) blister
 - (B) sprue
 - (C) riser
 - (D) pin hole
- Q.14 Which one of the following welding methods provides the highest heat flux (W/mm^2)?
- (A) Oxy-acetylene gas welding
 - (B) Tungsten inert gas welding
 - (C) Plasma arc welding
 - (D) Laser beam welding
- Q.15 The length, width and thickness of a steel sample are 400 mm, 40 mm and 20 mm, respectively. Its thickness needs to be uniformly reduced by 2 mm in a single pass by using horizontal slab milling. The milling cutter (diameter: 100 mm, width: 50 mm) has 20 teeth and rotates at 1200 rpm. The feed per tooth is 0.05 mm. The feed direction is along the length of the sample. If the over-travel distance is the same as the approach distance, the approach distance and time taken to complete the required machining task are
- (A) 14 mm, 18.4 s
 - (B) 21 mm, 28.9 s
 - (C) 21 mm, 39.4 s
 - (D) 14 mm, 21.4 s

- Q.16 The position vector \vec{OP} of point P (20, 10) is rotated anti-clockwise in X-Y plane by an angle $\theta = 30^\circ$ such that point P occupies position Q, as shown in the figure. The coordinates (x, y) of Q are

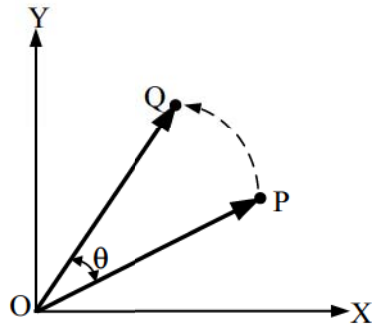

- (A) (13.40, 22.32) (B) (22.32, 8.26) (C) (12.32, 18.66) (D) (18.66, 12.32)
- Q.17 The table presents the demand of a product. By simple three-months moving average method, the demand-forecast of the product for the month of September is

Month	Demand
January	450
February	440
March	460
April	510
May	520
June	495
July	475
August	560

- (A) 490 (B) 510 (C) 530 (D) 536.67
- Q.18 Evaluation of $\int_2^4 x^3 dx$ using a 2-equal-segment trapezoidal rule gives a value of _____

- Q.19 A block of mass 10 kg rests on a horizontal floor. The acceleration due to gravity is 9.81 m/s^2 . The coefficient of static friction between the floor and the block is 0.2. A horizontal force of 10 N is applied on the block as shown in the figure. The magnitude of force of friction (in N) on the block is _____

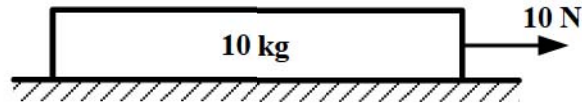

- Q.20 A cylindrical rod of diameter 10 mm and length 1.0 m is fixed at one end. The other end is twisted by an angle of 10° by applying a torque. If the maximum shear strain in the rod is $p \times 10^{-3}$, then p is equal to _____ (round off to two decimal places).
- Q.21 A solid cube of side 1 m is kept at a room temperature of 32°C . The coefficient of linear thermal expansion of the cube material is $1 \times 10^{-5} / ^\circ\text{C}$ and the bulk modulus is 200 GPa. If the cube is constrained all around and heated uniformly to 42°C , then the magnitude of volumetric (mean) stress (in MPa) induced due to heating is _____
- Q.22 During a high cycle fatigue test, a metallic specimen is subjected to cyclic loading with a mean stress of +140 MPa, and a minimum stress of -70 MPa. The R -ratio (minimum stress to maximum stress) for this cyclic loading is _____ (round off to one decimal place)
- Q.23 Water flows through a pipe with a velocity given by $\vec{V} = \left(\frac{4}{t} + x + y\right)\hat{j}$ m/s, where \hat{j} is the unit vector in the y direction, $t (> 0)$ is in seconds, and x and y are in meters. The magnitude of total acceleration at the point $(x, y) = (1, 1)$ at $t = 2$ s is _____ m/s^2 .
- Q.24 Air of mass 1 kg, initially at 300 K and 10 bar, is allowed to expand isothermally till it reaches a pressure of 1 bar. Assuming air as an ideal gas with gas constant of 0.287 kJ/kg.K, the change in entropy of air (in kJ/kg.K, round off to two decimal places) is _____

- Q.25 Consider the stress-strain curve for an ideal elastic-plastic strain hardening metal as shown in the figure. The metal was loaded in uniaxial tension starting from O. Upon loading, the stress-strain curve passes through initial yield point at P, and then strain hardens to point Q, where the loading was stopped. From point Q, the specimen was unloaded to point R, where the stress is zero. If the same specimen is reloaded in tension from point R, the value of stress at which the material yields again is _____ MPa.

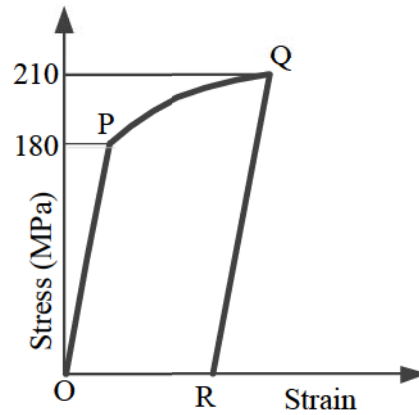

Q. 26 – Q. 55 carry two marks each.

Q.26 The set of equations

$$\begin{aligned}x + y + z &= 1 \\ax - ay + 3z &= 5 \\5x - 3y + az &= 6\end{aligned}$$

has infinite solutions, if $a =$

- (A) -3 (B) 3 (C) 4 (D) -4

Q.27 A harmonic function is analytic if it satisfies the Laplace equation.

If $u(x, y) = 2x^2 - 2y^2 + 4xy$ is a harmonic function, then its conjugate harmonic function $v(x, y)$ is

- (A) $4xy - 2x^2 + 2y^2 + \text{constant}$
(B) $4y^2 - 4xy + \text{constant}$
(C) $2x^2 - 2y^2 + xy + \text{constant}$
(D) $-4xy + 2y^2 - 2x^2 + \text{constant}$

Q.28 The variable x takes a value between 0 and 10 with uniform probability distribution. The variable y takes a value between 0 and 20 with uniform probability distribution. The probability of the sum of variables $(x + y)$ being greater than 20 is

- (A) 0 (B) 0.25 (C) 0.33 (D) 0.50

- Q.29 A car having weight W is moving in the direction as shown in the figure. The center of gravity (CG) of the car is located at height h from the ground, midway between the front and rear wheels. The distance between the front and rear wheels is l . The acceleration of the car is a , and acceleration due to gravity is g . The reactions on the front wheels (R_f) and rear wheels (R_r) are given by

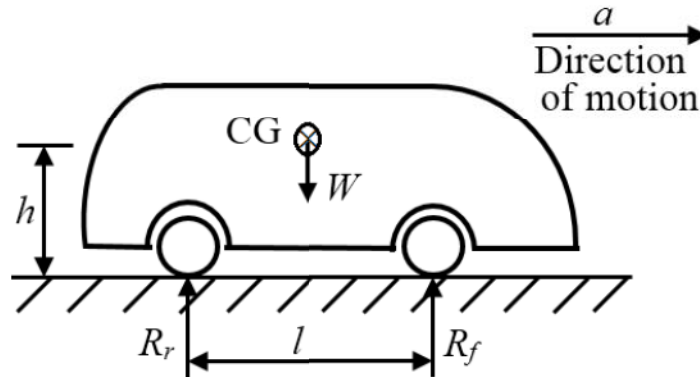

- (A) $R_f = R_r = \frac{W}{2} - \frac{W}{g} \left(\frac{h}{l} \right) a$
- (B) $R_f = \frac{W}{2} + \frac{W}{g} \left(\frac{h}{l} \right) a$; $R_r = \frac{W}{2} - \frac{W}{g} \left(\frac{h}{l} \right) a$
- (C) $R_f = \frac{W}{2} - \frac{W}{g} \left(\frac{h}{l} \right) a$; $R_r = \frac{W}{2} + \frac{W}{g} \left(\frac{h}{l} \right) a$
- (D) $R_f = R_r = \frac{W}{2} + \frac{W}{g} \left(\frac{h}{l} \right) a$

- Q.30 In a four bar planar mechanism shown in the figure, $AB = 5$ cm, $AD = 4$ cm and $DC = 2$ cm. In the configuration shown, both AB and DC are perpendicular to AD . The bar AB rotates with an angular velocity of 10 rad/s. The magnitude of angular velocity (in rad/s) of bar DC at this instant is

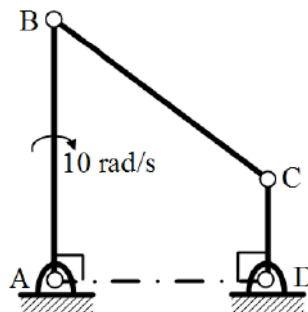

- (A) 0 (B) 10 (C) 15 (D) 25

Q.31 The rotor of a turbojet engine of an aircraft has a mass 180 kg and polar moment of inertia $10 \text{ kg}\cdot\text{m}^2$ about the rotor axis. The rotor rotates at a constant speed of 1100 rad/s in the clockwise direction when viewed from the front of the aircraft. The aircraft while flying at a speed of 800 km per hour takes a turn with a radius of 1.5 km to the left. The gyroscopic moment exerted by the rotor on the aircraft structure and the direction of motion of the nose when the aircraft turns, are

- (A) 1629.6 N·m and the nose goes up
- (B) 1629.6 N·m and the nose goes down
- (C) 162.9 N·m and the nose goes up
- (D) 162.9 N·m and the nose goes down

Q.32 The wall of a constant diameter pipe of length 1 m is heated uniformly with flux q'' by wrapping a heater coil around it. The flow at the inlet to the pipe is hydrodynamically fully developed. The fluid is incompressible and the flow is assumed to be laminar and steady all through the pipe. The bulk temperature of the fluid is equal to 0°C at the inlet and 50°C at the exit. The wall temperatures are measured at three locations, P, Q and R, as shown in the figure. The flow thermally develops after some distance from the inlet. The following measurements are made:

Point	P	Q	R
Wall Temp ($^\circ\text{C}$)	50	80	90

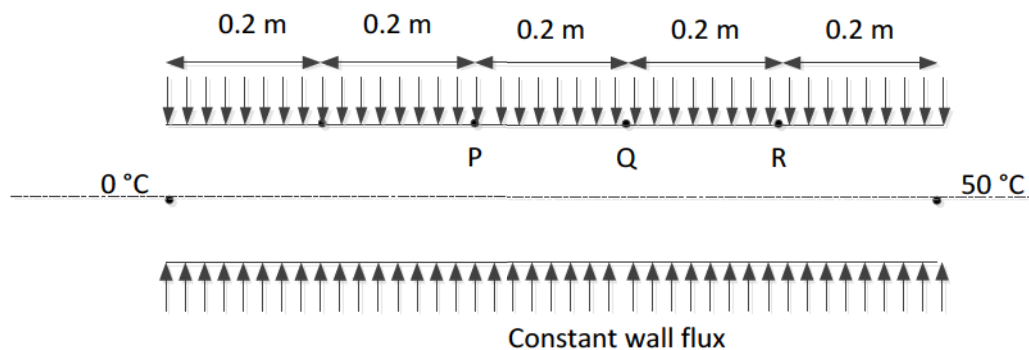

Among the locations P, Q and R, the flow is thermally developed at

- (A) P, Q and R
- (B) P and Q only
- (C) Q and R only
- (D) R only

- Q.33 A gas is heated in a duct as it flows over a resistance heater. Consider a 101 kW electric heating system. The gas enters the heating section of the duct at 100 kPa and 27 °C with a volume flow rate of 15 m³/s. If heat is lost from the gas in the duct to the surroundings at a rate of 51 kW, the exit temperature of the gas is

(Assume constant pressure, ideal gas, negligible change in kinetic and potential energies and constant specific heat; $C_p = 1$ kJ/kg·K; $R = 0.5$ kJ/kg·K.)

- (A) 32 °C (B) 37 °C (C) 53 °C (D) 76 °C

- Q.34 A plane-strain compression (forging) of a block is shown in the figure. The strain in the z -direction is zero. The yield strength (S_y) in uniaxial tension/compression of the material of the block is 300 MPa and it follows the Tresca (maximum shear stress) criterion. Assume that the entire block has started yielding. At a point where $\sigma_x = 40$ MPa (compressive) and $\tau_{xy} = 0$, the stress component σ_y is

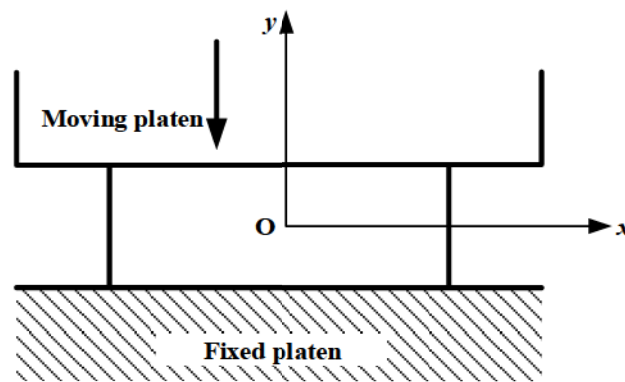

- (A) 340 MPa (compressive) (B) 340 MPa (tensile)
 (C) 260 MPa (compressive) (D) 260 MPa (tensile)

- Q.35 In orthogonal turning of a cylindrical tube of wall thickness 5 mm, the axial and the tangential cutting forces were measured as 1259 N and 1601 N, respectively. The measured chip thickness after machining was found to be 0.3 mm. The rake angle was 10° and the axial feed was 100 mm/min. The rotational speed of the spindle was 1000 rpm. Assuming the material to be perfectly plastic and Merchant's first solution, the shear strength of the material is closest to

- (A) 722 MPa (B) 920 MPa (C) 200 MPa (D) 875 MPa

Q.36 A circular shaft having diameter $65.00_{-0.05}^{+0.01}$ mm is manufactured by turning process. A $50\ \mu\text{m}$ thick coating of TiN is deposited on the shaft. Allowed variation in TiN film thickness is $\pm 5\ \mu\text{m}$. The minimum hole diameter (in mm) to just provide clearance fit is

- (A) 65.01 (B) 65.12 (C) 64.95 (D) 65.10

Q.37 Match the following sand mold casting defects with their respective causes.

Defect		Cause	
P	Blow hole	1	Poor collapsibility
Q	Misrun	2	Mold erosion
R	Hot tearing	3	Poor permeability
S	Wash	4	Insufficient fluidity

- (A) P-4, Q-3, R-1, S-2 (B) P-3, Q-4, R-2, S-1
 (C) P-2, Q-4, R-1, S-3 (D) P-3, Q-4, R-1, S-2

Q.38 A truss is composed of members AB, BC, CD, AD and BD, as shown in the figure. A vertical load of 10 kN is applied at point D. The magnitude of force (in kN) in the member BC is _____

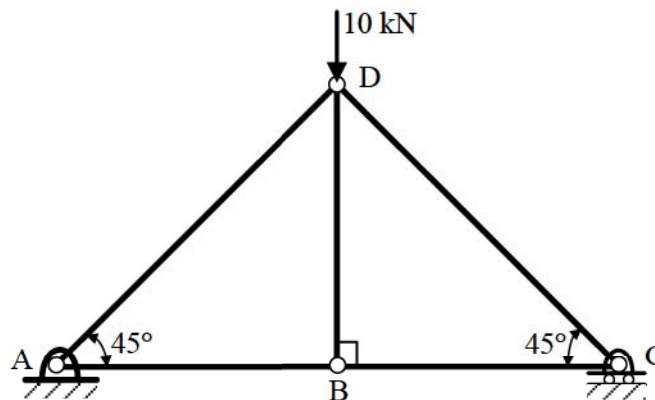

- Q.39 Consider an elastic straight beam of length $L = 10\pi$ m, with square cross-section of side $a = 5$ mm, and Young's modulus $E = 200$ GPa. This straight beam was bent in such a way that the two ends meet, to form a circle of mean radius R . Assuming that Euler-Bernoulli beam theory is applicable to this bending problem, the maximum tensile bending stress in the bent beam is _____ MPa.

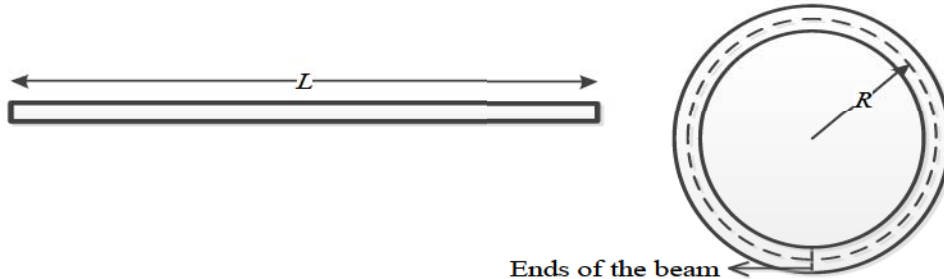

- Q.40 Consider a prismatic straight beam of length $L = \pi$ m, pinned at the two ends as shown in the figure. The beam has a square cross-section of side $p = 6$ mm. The Young's modulus $E = 200$ GPa, and the coefficient of thermal expansion $\alpha = 3 \times 10^{-6} \text{ K}^{-1}$. The minimum temperature rise required to cause Euler buckling of the beam is _____ K.

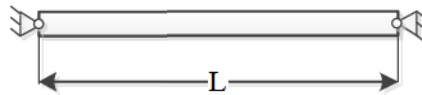

- Q.41 In a UTM experiment, a sample of length 100 mm, was loaded in tension until failure. The failure load was 40 kN. The displacement, measured using the cross-head motion, at failure, was 15 mm. The compliance of the UTM is constant and is given by $5 \times 10^{-8} \text{ m/N}$. The strain at failure in the sample is _____ %.
- Q.42 At a critical point in a component, the state of stress is given as $\sigma_{xx} = 100 \text{ MPa}$, $\sigma_{yy} = 220 \text{ MPa}$, $\sigma_{xy} = \sigma_{yx} = 80 \text{ MPa}$ and all other stress components are zero. The yield strength of the material is 468 MPa. The factor of safety on the basis of maximum shear stress theory is _____ (round off to one decimal place).

- Q.43 A uniform thin disk of mass 1 kg and radius 0.1 m is kept on a surface as shown in the figure. A spring of stiffness $k_1 = 400$ N/m is connected to the disk center A and another spring of stiffness $k_2 = 100$ N/m is connected at point B just above point A on the circumference of the disk. Initially, both the springs are unstretched. Assume pure rolling of the disk. For small disturbance from the equilibrium, the natural frequency of vibration of the system is _____ rad/s (round off to one decimal place).

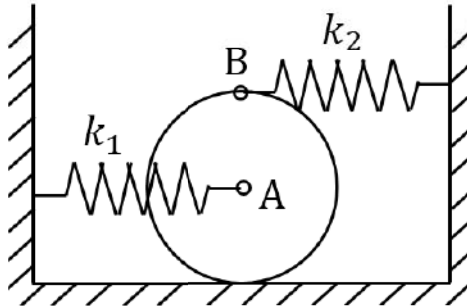

- Q.44 A single block brake with a short shoe and torque capacity of 250 N·m is shown. The cylindrical brake drum rotates anticlockwise at 100 rpm and the coefficient of friction is 0.25. The value of a , in mm (round off to one decimal place), such that the maximum actuating force P is 2000 N, is _____

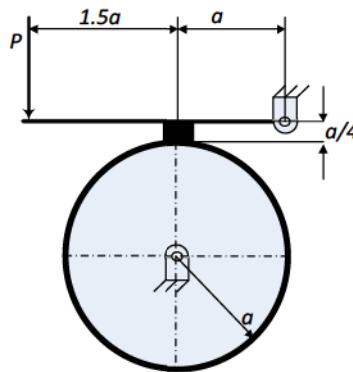

- Q.45 Two immiscible, incompressible, viscous fluids having same densities but different viscosities are contained between two infinite horizontal parallel plates, 2 m apart as shown below. The bottom plate is fixed and the upper plate moves to the right with a constant velocity of 3 m/s. With the assumptions of Newtonian fluid, steady, and fully developed laminar flow with zero pressure gradient in all directions, the momentum equations simplify to

$$\frac{d^2u}{dy^2} = 0.$$

If the dynamic viscosity of the lower fluid, μ_2 , is twice that of the upper fluid, μ_1 , then the velocity at the interface (round off to two decimal places) is _____ m/s.

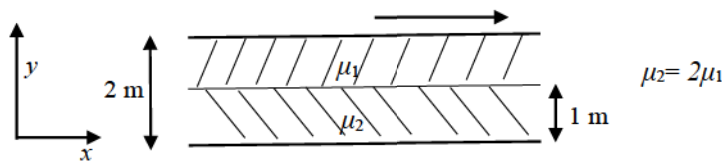

- Q.46 A cube of side 100 mm is placed at the bottom of an empty container on one of its faces. The density of the material of the cube is 800 kg/m^3 . Liquid of density 1000 kg/m^3 is now poured into the container. The minimum height to which the liquid needs to be poured into the container for the cube to just lift up is _____ mm.

- Q.47 Three slabs are joined together as shown in the figure. There is no thermal contact resistance at the interfaces. The center slab experiences a non-uniform internal heat generation with an average value equal to 10000 Wm^{-3} , while the left and right slabs have no internal heat generation. All slabs have thickness equal to 1 m and thermal conductivity of each slab is equal to $5 \text{ Wm}^{-1}\text{K}^{-1}$. The two extreme faces are exposed to fluid with heat transfer coefficient $100 \text{ Wm}^{-2}\text{K}^{-1}$ and bulk temperature 30°C as shown. The heat transfer in the slabs is assumed to be one dimensional and steady, and all properties are constant. If the left extreme face temperature T_1 is measured to be 100°C , the right extreme face temperature T_2 is _____ $^\circ\text{C}$.

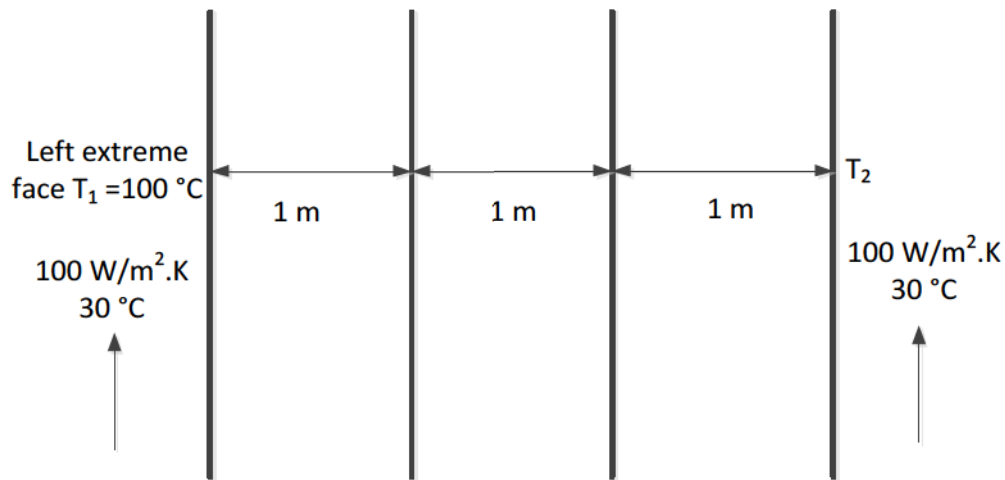

- Q.48 If one mole of H_2 gas occupies a rigid container with a capacity of 1000 litres and the temperature is raised from 27°C to 37°C , the change in pressure of the contained gas (round off to two decimal places), assuming ideal gas behaviour, is _____ Pa. ($R=8.314 \text{ J/mol}\cdot\text{K}$)

- Q.49 A steam power cycle with regeneration as shown below on the T - s diagram employs a single open feedwater heater for efficiency improvement. The fluids mix with each other in an open feedwater heater. The turbine is isentropic and the input (bleed) to the feedwater heater from the turbine is at state 2 as shown in the figure. Process 3-4 occurs in the condenser. The pump work is negligible. The input to the boiler is at state 5. The following information is available from the steam tables:

State	1	2	3	4	5	6
Enthalpy (kJ/kg)	3350	2800	2300	175	700	1000

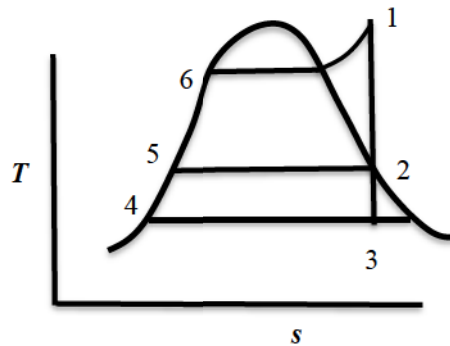

The mass flow rate of steam bled from the turbine as a percentage of the total mass flow rate at the inlet to the turbine at state 1 is _____

- Q.50 A gas turbine with air as the working fluid has an isentropic efficiency of 0.70 when operating at a pressure ratio of 3. Now, the pressure ratio of the turbine is increased to 5, while maintaining the same inlet conditions. Assume air as a perfect gas with specific heat ratio $\gamma = 1.4$. If the specific work output remains the same for both the cases, the isentropic efficiency of the turbine at the pressure ratio of 5 is _____ (round off to two decimal places)

- Q.51 The value of the following definite integral is _____ (round off to three decimal places)

$$\int_1^e (x \ln x) dx$$

- Q.52 In ASA system, the side cutting and end cutting edge angles of a sharp turning tool are 45° and 10° , respectively. The feed during cylindrical turning is 0.1 mm/rev. The center line average surface roughness (in μm , round off to one decimal place) of the generated surface is _____
- Q.53 Taylor's tool life equation is given by $VT^n = C$, where V is in m/min and T is in min. In a turning operation, two tools X and Y are used. For tool X, $n = 0.3$ and $C = 60$ and for tool Y, $n = 0.6$ and $C = 90$. Both the tools will have the same tool life for the cutting speed (in m/min, round off to one decimal place) of _____
- Q.54 Five jobs (J1, J2, J3, J4 and J5) need to be processed in a factory. Each job can be assigned to any of the five different machines (M1, M2, M3, M4 and M5). The time durations taken (in minutes) by the machines for each of the jobs, are given in the table. However, each job is assigned to a specific machine in such a way that the total processing time is minimum. The total processing time is _____ minutes.

	M1	M2	M3	M4	M5
J1	40	30	50	50	58
J2	26	38	60	26	38
J3	40	34	28	24	30
J4	28	40	40	32	48
J5	28	32	38	22	44

- Q.55 A project consists of six activities. The immediate predecessor of each activity and the estimated duration is also provided in the table below:

Activity	Immediate predecessor	Estimated duration (weeks)
P	-	5
Q	-	1
R	Q	2
S	P, R	4
T	P	6
U	S, T	3

If all activities other than S take the estimated amount of time, the maximum duration (in weeks) of the activity S without delaying the completion of the project is _____

END OF THE QUESTION PAPER

Q.No.	Type	Section	Key	Marks
1	MCQ	GA	C	1
2	MCQ	GA	C	1
3	MCQ	GA	D	1
4	MCQ	GA	C	1
5	MCQ	GA	B	1
6	MCQ	GA	C	2
7	MCQ	GA	D	2
8	MCQ	GA	A	2
9	MCQ	GA	C	2
10	MCQ	GA	D	2
1	MCQ	ME	B	1
2	MCQ	ME	B	1
3	MCQ	ME	C	1
4	MCQ	ME	A	1
5	MCQ	ME	C	1
6	MCQ	ME	B	1
7	MCQ	ME	B	1
8	MCQ	ME	C	1
9	MCQ	ME	A	1
10	MCQ	ME	A	1
11	MCQ	ME	D	1
12	MCQ	ME	A	1
13	MCQ	ME	B	1

Q.No.	Type	Section	Key	Marks
14	MCQ	ME	D	1
15	MCQ	ME	D	1
16	MCQ	ME	C	1
17	MCQ	ME	B	1
18	NAT	ME	63 to 63	1
19	NAT	ME	10 to 10	1
20	NAT	ME	0.80 to 0.90	1
21	NAT	ME	59.5 to 60.5	1
22	NAT	ME	-0.2 to -0.2	1
23	NAT	ME	3 to 3	1
24	NAT	ME	0.64 to 0.68	1
25	NAT	ME	210 to 210	1
26	MCQ	ME	C	2
27	MCQ	ME	A	2
28	MCQ	ME	B	2
29	MCQ	ME	C	2
30	MCQ	ME	D	2
31	MCQ	ME	B	2
32	MCQ	ME	C	2
33	MCQ	ME	A	2
34	MCQ	ME	A	2
35	MCQ	ME	A	2
36	MCQ	ME	B	2

Q.No.	Type	Section	Key	Marks
37	MCQ	ME	D	2
38	NAT	ME	4.98 to 5.02	2
39	NAT	ME	99 to 101	2
40	NAT	ME	1 to 1	2
41	NAT	ME	12 to 14	2
42	NAT	ME	1.7 to 1.9	2
43	NAT	ME	23.0 to 24.0	2
44	NAT	ME	212.0 to 213.0	2
45	NAT	ME	0.98 to 1.02	2
46	NAT	ME	80 to 80	2
47	NAT	ME	60 to 60	2
48	NAT	ME	82.14 to 84.14	2
49	NAT	ME	19 to 21	2
50	NAT	ME	0.50 to 0.52	2
51	NAT	ME	2.090 to 2.104	2
52	NAT	ME	3.5 to 3.9	2
53	NAT	ME	38.0 to 42.0	2
54	NAT	ME	146 to 146	2
55	NAT	ME	6 to 6	2

SESSION - 2

Q. 6 – Q. 10 carry two marks each.

Q.6 Fiscal deficit was 4% of the GDP in 2015 and that increased to 5% in 2016. If the GDP increased by 10% from 2015 to 2016, the percentage increase in the actual fiscal deficit is ____.

- (A) 37.50 (B) 35.70 (C) 25.00 (D) 10.00

Q.7 Two pipes P and Q can fill a tank in 6 hours and 9 hours respectively, while a third pipe R can empty the tank in 12 hours. Initially, P and R are open for 4 hours. Then P is closed and Q is opened. After 6 more hours R is closed. The total time taken to fill the tank (in hours) is ____.

- (A) 13.50 (B) 14.50 (C) 15.50 (D) 16.50

Q.8 While teaching a creative writing class in India, I was surprised at receiving stories from the students that were all set in distant places: in the American West with cowboys and in Manhattan penthouses with clinking ice cubes. This was, till an eminent Caribbean writer gave the writers in the once-colonised countries the confidence to see the shabby lives around them as worthy of being “told”.

The writer of this passage is surprised by the creative writing assignments of his students, because _____.

- (A) Some of the students had written stories set in foreign places
 (B) None of the students had written stories set in India
 (C) None of the students had written about ice cubes and cowboys
 (D) Some of the students had written about ice cubes and cowboys

Q.9 Mola is a digital platform for taxis in a city. It offers three types of rides – Pool, Mini and Prime. The Table below presents the number of rides for the past four months. The platform earns one US dollar per ride. What is the percentage share of revenue contributed by Prime to the total revenues of Mola, for the entire duration?

Type	Month			
	January	February	March	April
Pool	170	320	215	190
Mini	110	220	180	70
Prime	75	180	120	90

- (A) 16.24 (B) 23.97 (C) 25.86 (D) 38.74

Q.10 X is an online media provider. By offering unlimited and exclusive online content at attractive prices for a loyalty membership, X is almost forcing its customers towards its loyalty membership. If its loyalty membership continues to grow at its current rate, within the next eight years more households will be watching X than cable television.

Which one of the following statements can be inferred from the above paragraph?

- (A) Most households that subscribe to X's loyalty membership discontinue watching cable television
- (B) Non-members prefer to watch cable television
- (C) Cable television operators don't subscribe to X's loyalty membership
- (D) The X is cancelling accounts of non-members

END OF THE QUESTION PAPER

Q. 1 – Q. 25 carry one mark each.

Q.1 In matrix equation $[A]\{X\}=\{R\}$,

$$[A]=\begin{bmatrix} 4 & 8 & 4 \\ 8 & 16 & -4 \\ 4 & -4 & 15 \end{bmatrix}, \{X\}=\begin{Bmatrix} 2 \\ 1 \\ 4 \end{Bmatrix} \text{ and } \{R\}=\begin{Bmatrix} 32 \\ 16 \\ 64 \end{Bmatrix}.$$

One of the eigenvalues of matrix $[A]$ is

- (A) 4 (B) 8 (C) 15 (D) 16

Q.2 The directional derivative of the function $f(x,y) = x^2 + y^2$ along a line directed from (0,0) to (1,1), evaluated at the point $x = 1, y = 1$ is

- (A) $\sqrt{2}$ (B) 2 (C) $2\sqrt{2}$ (D) $4\sqrt{2}$

Q.3 The differential equation $\frac{dy}{dx} + 4y = 5$ is valid in the domain $0 \leq x \leq 1$ with $y(0) = 2.25$. The solution of the differential equation is

- (A) $y = e^{-4x} + 5$ (B) $y = e^{-4x} + 1.25$
(C) $y = e^{4x} + 5$ (D) $y = e^{4x} + 1.25$

Q.4 An analytic function $f(z)$ of complex variable $z = x + iy$ may be written as $f(z) = u(x, y) + iv(x, y)$. Then, $u(x, y)$ and $v(x, y)$ must satisfy

- (A) $\frac{\partial u}{\partial x} = \frac{\partial v}{\partial y}$ and $\frac{\partial u}{\partial y} = \frac{\partial v}{\partial x}$
- (B) $\frac{\partial u}{\partial x} = \frac{\partial v}{\partial y}$ and $\frac{\partial u}{\partial y} = -\frac{\partial v}{\partial x}$
- (C) $\frac{\partial u}{\partial x} = -\frac{\partial v}{\partial y}$ and $\frac{\partial u}{\partial y} = \frac{\partial v}{\partial x}$
- (D) $\frac{\partial u}{\partial x} = -\frac{\partial v}{\partial y}$ and $\frac{\partial u}{\partial y} = -\frac{\partial v}{\partial x}$

Q.5 A rigid triangular body, PQR, with sides of equal length of 1 unit moves on a flat plane. At the instant shown, edge QR is parallel to the x-axis, and the body moves such that velocities of points P and R are V_P and V_R , in the x and y directions, respectively. The magnitude of the angular velocity of the body is

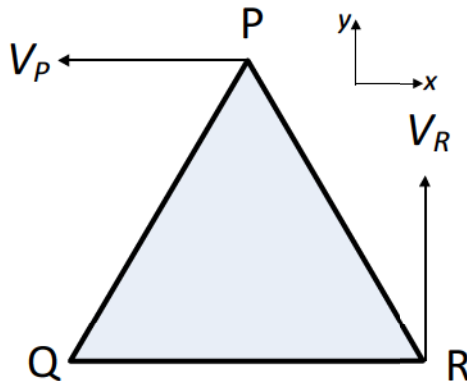

- (A) $2V_R$ (B) $2V_P$ (C) $V_R/\sqrt{3}$ (D) $V_P/\sqrt{3}$

Q.6 Consider a linear elastic rectangular thin sheet of metal, subjected to uniform uniaxial tensile stress of 100 MPa along the length direction. Assume plane stress conditions in the plane normal to the thickness. The Young's modulus $E = 200$ MPa and Poisson's ratio $\nu = 0.3$ are given. The principal strains in the plane of the sheet are

- (A) (0.35, -0.15) (B) (0.5, 0.0) (C) (0.5, -0.15) (D) (0.5, -0.5)

Q.7 A spur gear has pitch circle diameter D and number of teeth T . The circular pitch of the gear is

- (A) $\frac{\pi D}{T}$ (B) $\frac{T}{D}$ (C) $\frac{D}{T}$ (D) $\frac{2\pi D}{T}$

Q.8 Endurance limit of a beam subjected to pure bending decreases with

- (A) decrease in the surface roughness and decrease in the size of the beam
(B) increase in the surface roughness and decrease in the size of the beam
(C) increase in the surface roughness and increase in the size of the beam
(D) decrease in the surface roughness and increase in the size of the beam

Q.9 A two-dimensional incompressible frictionless flow field is given by $\vec{u} = x\hat{i} - y\hat{j}$. If ρ is the density of the fluid, the expression for pressure gradient vector at any point in the flow field is given as

- (A) $\rho(x\hat{i} + y\hat{j})$ (B) $-\rho(x\hat{i} + y\hat{j})$
(C) $\rho(x\hat{i} - y\hat{j})$ (D) $-\rho(x^2\hat{i} + y^2\hat{j})$

- Q.10 Sphere 1 with a diameter of 0.1 m is completely enclosed by another sphere 2 of diameter 0.4 m. The view factor F_{12} is
- (A) 0.0625 (B) 0.25
(C) 0.5 (D) 1.0
- Q.11 One-dimensional steady state heat conduction takes place through a solid whose cross-sectional area varies linearly in the direction of heat transfer. Assume there is no heat generation in the solid and the thermal conductivity of the material is constant and independent of temperature. The temperature distribution in the solid is
- (A) Linear (B) Quadratic
(C) Logarithmic (D) Exponential
- Q.12 For a simple compressible system, v , s , p and T are specific volume, specific entropy, pressure and temperature, respectively. As per Maxwell's relations, $\left(\frac{\partial v}{\partial s}\right)_p$ is equal to
- (A) $\left(\frac{\partial s}{\partial T}\right)_p$ (B) $\left(\frac{\partial p}{\partial v}\right)_T$
(C) $-\left(\frac{\partial T}{\partial v}\right)_p$ (D) $\left(\frac{\partial T}{\partial p}\right)_s$
- Q.13 Which one of the following modifications of the simple ideal Rankine cycle increases the thermal efficiency and reduces the moisture content of the steam at the turbine outlet?
- (A) Increasing the boiler pressure.
(B) Decreasing the boiler pressure.
(C) Increasing the turbine inlet temperature.
(D) Decreasing the condenser pressure.

- Q.14 Hardenability of steel is a measure of
- (A) the ability to harden when it is cold worked
 - (B) the maximum hardness that can be obtained when it is austenitized and then quenched
 - (C) the depth to which required hardening is obtained when it is austenitized and then quenched
 - (D) the ability to retain its hardness when it is heated to elevated temperatures
- Q.15 The fluidity of molten metal of cast alloys (without any addition of fluxes) increases with increase in
- (A) viscosity
 - (B) surface tension
 - (C) freezing range
 - (D) degree of superheat
- Q.16 The cold forming process in which a hardened tool is pressed against a workpiece (when there is relative motion between the tool and the workpiece) to produce a roughened surface with a regular pattern is
- (A) Roll forming
 - (B) Strip rolling
 - (C) Knurling
 - (D) Chamfering
- Q.17 The most common limit gage used for inspecting the hole diameter is
- (A) Snap gage
 - (B) Ring gage
 - (C) Plug gage
 - (D) Master gage
- Q.18 The transformation matrix for mirroring a point in $x - y$ plane about the line $y = x$ is given by
- (A) $\begin{bmatrix} 1 & 0 \\ 0 & -1 \end{bmatrix}$
 - (B) $\begin{bmatrix} -1 & 0 \\ 0 & 1 \end{bmatrix}$
 - (C) $\begin{bmatrix} 0 & 1 \\ 1 & 0 \end{bmatrix}$
 - (D) $\begin{bmatrix} 0 & -1 \\ -1 & 0 \end{bmatrix}$

Q.19 If x is the mean of data 3, x , 2 and 4, then the mode is _____

Q.20 The figure shows an idealized plane truss. If a horizontal force of 300 N is applied at point A, then the magnitude of the force produced in member CD is _____ N.

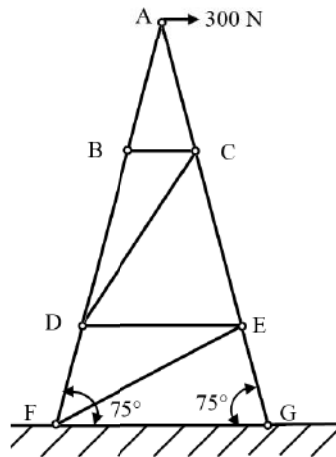

Q.21 The state of stress at a point in a component is represented by a Mohr's circle of radius 100 MPa centered at 200 MPa on the normal stress axis. On a plane passing through the same point, the normal stress is 260 MPa. The magnitude of the shear stress on the same plane at the same point is _____ MPa.

Q.22 A wire of circular cross-section of diameter 1.0 mm is bent into a circular arc of radius 1.0 m by application of pure bending moments at its ends. The Young's modulus of the material of the wire is 100 GPa. The maximum tensile stress developed in the wire is _____ MPa.

Q.23 Water enters a circular pipe of length $L = 5.0$ m and diameter $D = 0.20$ m with Reynolds number $Re_D = 500$. The velocity profile at the inlet of the pipe is uniform while it is parabolic at the exit. The Reynolds number at the exit of the pipe is _____.

- Q.24 A thin vertical flat plate of height L , and infinite width perpendicular to the plane of the figure, is losing heat to the surroundings by natural convection. The temperatures of the plate and the surroundings, and the properties of the surrounding fluid, are constant. The relationship between the average Nusselt and Rayleigh numbers is given as $Nu = K Ra^{1/4}$, where K is a constant. The length scales for Nusselt and Rayleigh numbers are the height of the plate. The height of the plate is increased to $16L$ keeping all other factors constant.

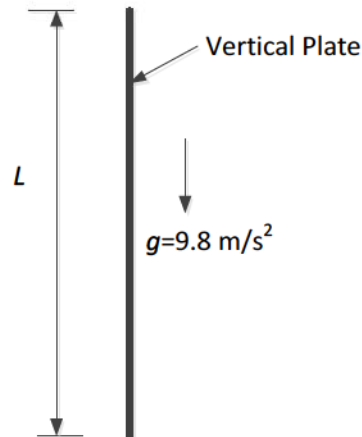

If the average heat transfer coefficient for the first plate is h_1 and that for the second plate is h_2 , the value of the ratio h_1/h_2 is _____.

- Q.25 In an electrical discharge machining process, the breakdown voltage across inter electrode gap (IEG) is 200 V and the capacitance of the RC circuit is 50 μF . The energy (in J) released per spark across the IEG is _____

Q. 26 – Q. 55 carry two marks each.

Q.26 Given a vector $\vec{u} = \frac{1}{3}(-y^3 \hat{i} + x^3 \hat{j} + z^3 \hat{k})$ and \hat{n} as the unit normal vector to the surface of the hemisphere ($x^2 + y^2 + z^2 = 1; z \geq 0$), the value of integral $\int (\nabla \times \vec{u}) \cdot \hat{n} \, dS$ evaluated on the curved surface of the hemisphere S is

(A) $-\frac{\pi}{2}$

(B) $\frac{\pi}{3}$

(C) $\frac{\pi}{2}$

(D) π

Q.27 A differential equation is given as

$$x^2 \frac{d^2 y}{dx^2} - 2x \frac{dy}{dx} + 2y = 4.$$

The solution of the differential equation in terms of arbitrary constants C_1 and C_2 is

(A) $y = C_1 x^2 + C_2 x + 2$

(B) $y = \frac{C_1}{x^2} + C_2 x + 2$

(C) $y = C_1 x^2 + C_2 x + 4$

(D) $y = \frac{C_1}{x^2} + C_2 x + 4$

Q.28 The derivative of $f(x) = \cos(x)$ can be estimated using the approximation

$$f'(x) = \frac{f(x+h) - f(x-h)}{2h}.$$

The percentage error is calculated as

$$\left(\frac{\text{Exact value} - \text{Approximate value}}{\text{Exact value}} \right) \times 100.$$

The percentage error in the derivative of

$f(x)$ at $x = \pi/6$ radian, choosing $h = 0.1$ radian, is

(A) $< 0.1 \%$

(B) $> 0.1 \%$ and $< 1 \%$

(C) $> 1 \%$ and $< 5 \%$

(D) $> 5 \%$

Q.29 A ball of mass 3 kg moving with a velocity of 4 m/s undergoes a perfectly-elastic direct-central impact with a stationary ball of mass m . After the impact is over, the kinetic energy of the 3 kg ball is 6 J. The possible value(s) of m is/are

- (A) 1 kg only (B) 6 kg only (C) 1 kg, 6 kg (D) 1 kg, 9 kg

Q.30 Consider two concentric circular cylinders of different materials M and N in contact with each other at $r = b$, as shown below. The interface at $r = b$ is frictionless. The composite cylinder system is subjected to internal pressure P . Let (u_r^M, u_θ^M) and $(\sigma_{rr}^M, \sigma_{\theta\theta}^M)$ denote the radial and tangential displacement and stress components, respectively, in material M. Similarly, (u_r^N, u_θ^N) and $(\sigma_{rr}^N, \sigma_{\theta\theta}^N)$ denote the radial and tangential displacement and stress components, respectively, in material N. The boundary conditions that need to be satisfied at the frictionless interface between the two cylinders are:

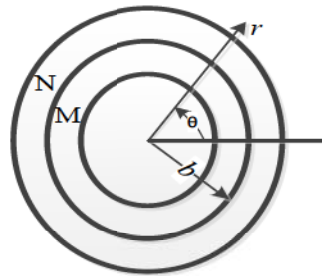

- (A) $u_r^M = u_r^N$ and $\sigma_{rr}^M = \sigma_{rr}^N$ only
 (B) $u_r^M = u_r^N$ and $\sigma_{rr}^M = \sigma_{rr}^N$ and $u_\theta^M = u_\theta^N$ and $\sigma_{\theta\theta}^M = \sigma_{\theta\theta}^N$
 (C) $u_\theta^M = u_\theta^N$ and $\sigma_{\theta\theta}^M = \sigma_{\theta\theta}^N$ only
 (D) $\sigma_{rr}^M = \sigma_{rr}^N$ and $\sigma_{\theta\theta}^M = \sigma_{\theta\theta}^N$ only

Q.31 A prismatic, straight, elastic, cantilever beam is subjected to a linearly distributed transverse load as shown below. If the beam length is L , Young's modulus E , and area moment of inertia I , the magnitude of the maximum deflection is

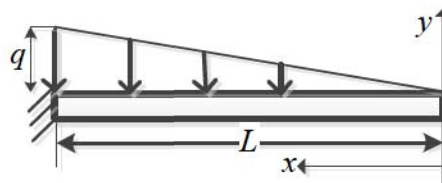

- (A) $\frac{qL^4}{15EI}$ (B) $\frac{qL^4}{30EI}$ (C) $\frac{qL^4}{10EI}$ (D) $\frac{qL^4}{60EI}$

- Q.32 A slender uniform rigid bar of mass m is hinged at O and supported by two springs, with stiffnesses $3k$ and k , and a damper with damping coefficient c , as shown in the figure. For the system to be critically damped, the ratio c/\sqrt{km} should be

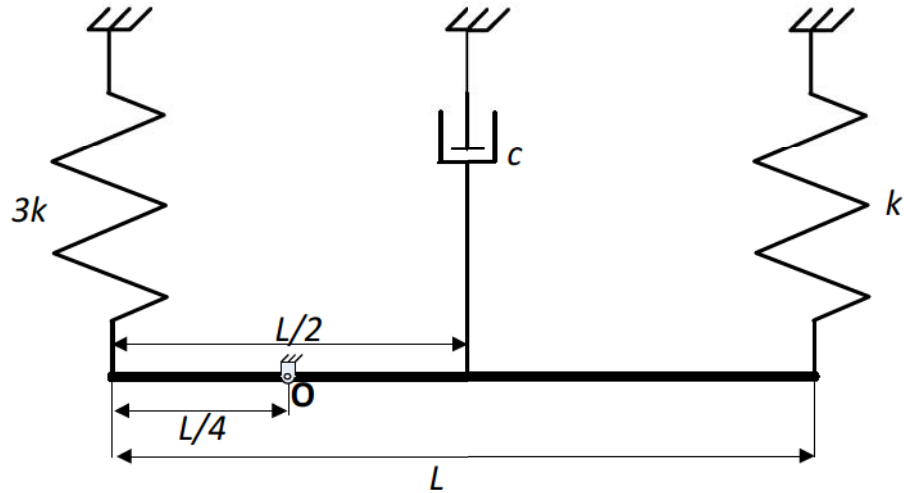

(A) 2

(B) 4

(C) $2\sqrt{7}$ (D) $4\sqrt{7}$

- Q.33 The figure shows a heat engine (HE) working between two reservoirs. The amount of heat (Q_2) rejected by the heat engine is drawn by a heat pump (HP). The heat pump receives the entire work output (W) of the heat engine. If temperatures, $T_1 > T_3 > T_2$, then the relation between the efficiency (η) of the heat engine and the coefficient of performance (COP) of the heat pump is

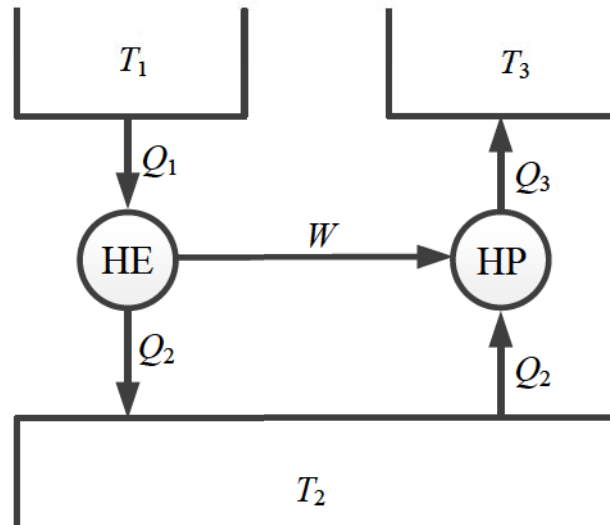

- (A) $\text{COP} = \eta$ (B) $\text{COP} = 1 + \eta$
(C) $\text{COP} = \eta^{-1}$ (D) $\text{COP} = \eta^{-1} - 1$

Q.34 The binary phase diagram of metals P and Q is shown in the figure. An alloy X containing 60% P and 40% Q (by weight) is cooled from liquid to solid state. The fractions of solid and liquid (in weight percent) at 1250 °C, respectively, will be

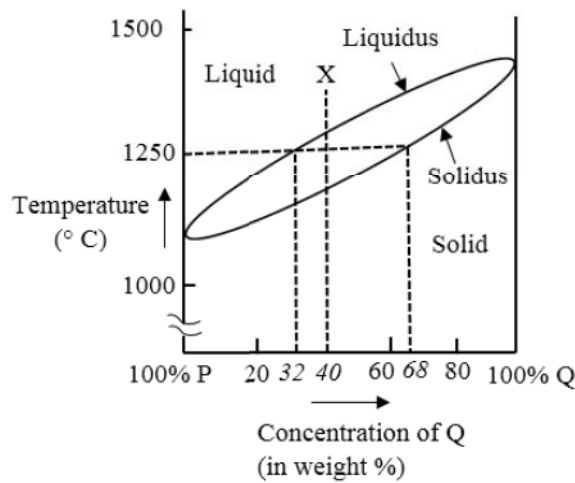

- (A) 77.8% and 22.2%
- (B) 22.2% and 77.8%
- (C) 68.0% and 32.0%
- (D) 32.0% and 68.0%

Q.35 The activities of a project, their duration and the precedence relationships are given in the table. For example, in a precedence relationship “X < Y, Z” means that X is predecessor of activities Y and Z. The time to complete the activities along the critical path is _____ weeks.

Activity	Duration (Weeks)	Precedence Relationship
A	5	A < B, C, D
B	7	B < E, F, G
C	10	C < I
D	6	D < G
E	3	E < H
F	9	F < I
G	7	G < I
H	4	H < I
I	2	---

- (A) 17
- (B) 21
- (C) 23
- (D) 25

- Q.36 The crank of a slider-crank mechanism rotates counter-clockwise (CCW) with a constant angular velocity ω , as shown. Assume the length of the crank to be r .

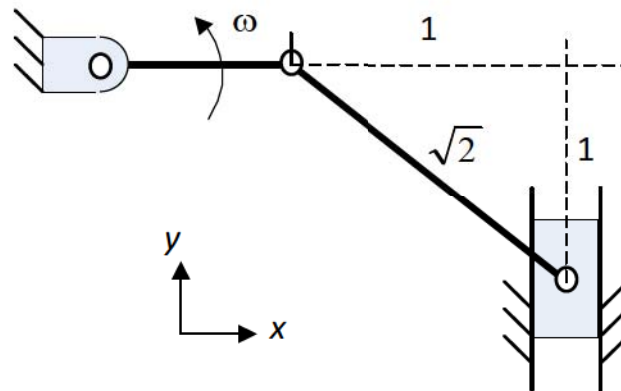

Using exact analysis, the acceleration of the slider in the y -direction, at the instant shown, where the crank is parallel to x -axis, is given by

- (A) $-\omega^2 r$ (B) $2\omega^2 r$ (C) $\omega^2 r$ (D) $-2\omega^2 r$
- Q.37 A horizontal cantilever beam of circular cross-section, length 1.0 m and flexural rigidity $EI = 200 \text{ N}\cdot\text{m}^2$ is subjected to an applied moment $M_A = 1.0 \text{ N}\cdot\text{m}$ at the free end as shown in the figure. The magnitude of the vertical deflection of the free end is _____ mm (round off to one decimal place).

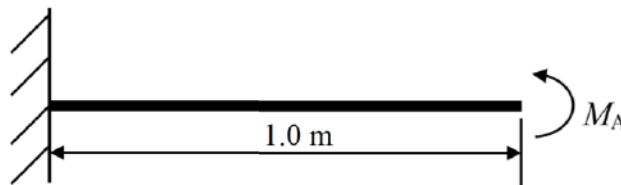

- Q.38 Two masses A and B having mass m_a and m_b , respectively, lying in the plane of the figure shown, are rigidly attached to a shaft which revolves about an axis through O perpendicular to the plane of the figure. The radii of rotation of the masses m_a and m_b are r_a and r_b , respectively. The angle between lines OA and OB is 90° . If $m_a = 10$ kg, $m_b = 20$ kg, $r_a = 200$ mm and $r_b = 400$ mm, then the balance mass to be placed at a radius of 200 mm is _____ kg (round off to two decimal places).

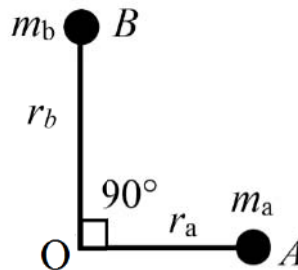

- Q.39 A four bar mechanism is shown in the figure. The link numbers are mentioned near the links. Input link 2 is rotating anticlockwise with a constant angular speed ω_2 . Length of different links are:

$$O_2O_4 = O_2A = L,$$

$$AB = O_4B = \sqrt{2}L.$$

The magnitude of the angular speed of the output link 4 is ω_4 at the instant when link 2 makes an angle of 90° with O_2O_4 as shown. The ratio $\frac{\omega_4}{\omega_2}$ is _____ (round off to two decimal places).

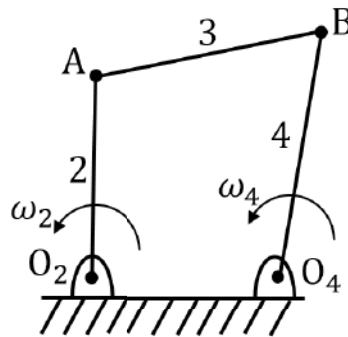

- Q.40 The probability that a part manufactured by a company will be defective is 0.05. If 15 such parts are selected randomly and inspected, then the probability that at least two parts will be defective is _____ (round off to two decimal places).
- Q.41 A uniform disc with radius r and a mass of m kg is mounted centrally on a horizontal axle of negligible mass and length of $1.5r$. The disc spins counter-clockwise about the axle with angular speed ω , when viewed from the right-hand side bearing, Q. The axle precesses about a vertical axis at $\omega_p = \omega / 10$ in the clockwise direction when viewed from above. Let R_P and R_Q (positive upwards) be the resultant reaction forces due to the mass and the gyroscopic effect, at bearings P and Q, respectively. Assuming $\omega^2 r = 300 \text{ m/s}^2$ and $g = 10 \text{ m/s}^2$, the ratio of the larger to the smaller bearing reaction force (considering appropriate signs) is _____

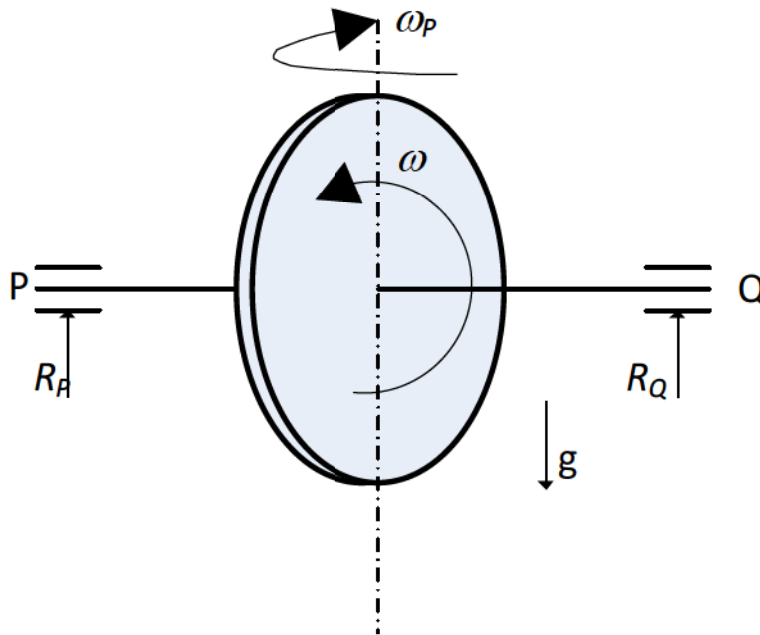

- Q.42 A short shoe external drum brake is shown in the figure. The diameter of the brake drum is 500 mm. The dimensions $a = 1000$ mm, $b = 500$ mm and $c = 200$ mm. The coefficient of friction between the drum and the shoe is 0.35. The force applied on the lever $F = 100$ N as shown in the figure. The drum is rotating anti-clockwise. The braking torque on the drum is _____ N·m (round off to two decimal places).

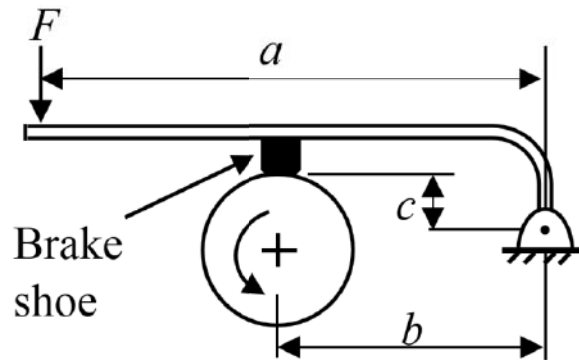

- Q.43 Water flows through two different pipes **A** and **B** of the same circular cross-section but at different flow rates. The length of pipe **A** is 1.0 m and that of pipe **B** is 2.0 m. The flow in both the pipes is laminar and fully developed. If the frictional head loss across the length of the pipes is same, the ratio of volume flow rates Q_B/Q_A is _____ (round off to two decimal places).
- Q.44 The aerodynamic drag on a sports car depends on its shape. The car has a drag coefficient of 0.1 with the windows and the roof closed. With the windows and the roof open, the drag coefficient becomes 0.8. The car travels at 44 km/h with the windows and roof closed. For the same amount of power needed to overcome the aerodynamic drag, the speed of the car with the windows and roof open (round off to two decimal places), is _____ km/h (The density of air and the frontal area may be assumed to be constant).

- Q.45 Three sets of parallel plates LM, NR and PQ are given in Figures 1, 2 and 3. The view factor F_{IJ} is defined as the fraction of radiation leaving plate I that is intercepted by plate J . Assume that the values of F_{LM} and F_{NR} are 0.8 and 0.4, respectively. The value of F_{PQ} (round off to one decimal place) is _____.

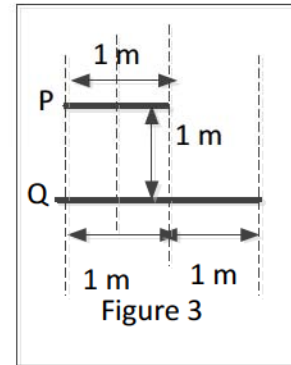
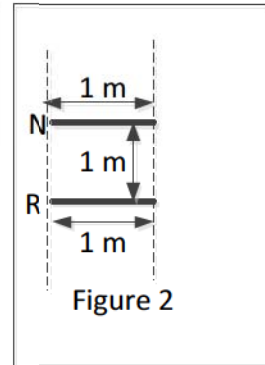
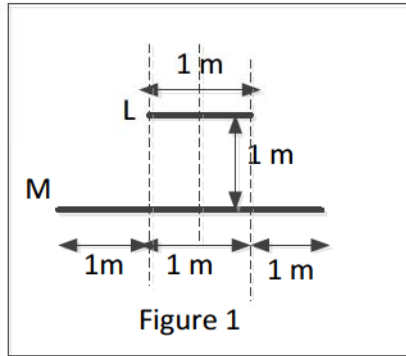

- Q.46 Hot and cold fluids enter a parallel flow double tube heat exchanger at 100°C and 15°C , respectively. The heat capacity rates of hot and cold fluids are $C_h = 2000\text{ W/K}$ and $C_c = 1200\text{ W/K}$, respectively. If the outlet temperature of the cold fluid is 45°C , the log mean temperature difference (LMTD) of the heat exchanger is _____ K (round off to two decimal places).
- Q.47 Water flowing at the rate of 1 kg/s through a system is heated using an electric heater such that the specific enthalpy of the water increases by 2.50 kJ/kg and the specific entropy increases by $0.007\text{ kJ/kg}\cdot\text{K}$. The power input to the electric heater is 2.50 kW . There is no other work or heat interaction between the system and the surroundings. Assuming an ambient temperature of 300 K , the irreversibility rate of the system is _____ kW (round off to two decimal places).
- Q.48 An idealized centrifugal pump (blade outer radius of 50 mm) consumes 2 kW power while running at 3000 rpm . The entry of the liquid into the pump is axial and exit from the pump is radial with respect to impeller. If the losses are neglected, then the mass flow rate of the liquid through the pump is _____ kg/s (round off to two decimal places).

Q.49 An air standard Otto cycle has thermal efficiency of 0.5 and the mean effective pressure of the cycle is 1000 kPa. For air, assume specific heat ratio $\gamma = 1.4$ and specific gas constant $R = 0.287$ kJ/kg·K. If the pressure and temperature at the beginning of the compression stroke are 100 kPa and 300 K, respectively, then the specific net work output of the cycle is _____ kJ/kg (round off to two decimal places).

Q.50 The figure shows a pouring arrangement for casting of a metal block. Frictional losses are negligible. The acceleration due to gravity is 9.81 m/s². The time (in s, round off to two decimal places) to fill up the mold cavity (of size 40 cm × 30 cm × 15 cm) is _____

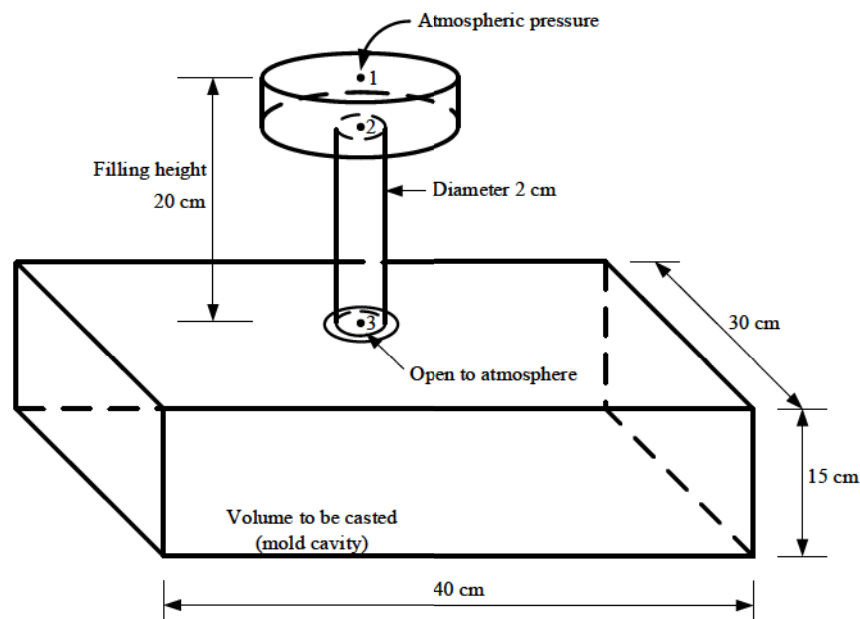

Q.51 A gas tungsten arc welding operation is performed using a current of 250 A and an arc voltage of 20 V at a welding speed of 5 mm/s. Assuming that the arc efficiency is 70%, the net heat input per unit length of the weld will be _____ kJ/mm (round off to one decimal place).

- Q.52 The thickness of a sheet is reduced by rolling (without any change in width) using 600 mm diameter rolls. Neglect elastic deflection of the rolls and assume that the coefficient of friction at the roll-workpiece interface is 0.05. The sheet enters the rotating rolls unaided. If the initial sheet thickness is 2 mm, the minimum possible final thickness that can be produced by this process in a single pass is _____ mm (round off to two decimal places).
- Q.53 A through hole is drilled in an aluminum alloy plate of 15 mm thickness with a drill bit of diameter 10 mm, at a feed of 0.25 mm/rev and a spindle speed of 1200 rpm. If the specific energy required for cutting this material is $0.7 \text{ N}\cdot\text{m}/\text{mm}^3$, the power required for drilling is _____ W (round off to two decimal places).
- Q.54 In an orthogonal machining with a single point cutting tool of rake angle 10° , the uncut chip thickness and the chip thickness are 0.125 mm and 0.22 mm, respectively. Using Merchant's first solution for the condition of minimum cutting force, the coefficient of friction at the chip-tool interface is _____ (round off to two decimal places).
- Q.55 The annual demand of valves per year in a company is 10,000 units. The current order quantity is 400 valves per order. The holding cost is Rs. 24 per valve per year and the ordering cost is Rs. 400 per order. If the current order quantity is changed to Economic Order Quantity, then the saving in the total cost of inventory per year will be Rs. _____ (round off to two decimal places).

END OF THE QUESTION PAPER

Q.No.	Type	Section	Key	Marks
1	MCQ	GA	B	1
2	MCQ	GA	A	1
3	MCQ	GA	B	1
4	MCQ	GA	Mark to All	1
5	MCQ	GA	D	1
6	MCQ	GA	A	2
7	MCQ	GA	B	2
8	MCQ	GA	B	2
9	MCQ	GA	B	2
10	MCQ	GA	A	2
1	MCQ	ME	D	1
2	MCQ	ME	C	1
3	MCQ	ME	B	1
4	MCQ	ME	B	1
5	MCQ	ME	A	1
6	MCQ	ME	C	1
7	MCQ	ME	A	1
8	MCQ	ME	C	1
9	MCQ	ME	B	1
10	MCQ	ME	D	1
11	MCQ	ME	C	1
12	MCQ	ME	D	1

Q.No.	Type	Section	Key	Marks
13	MCQ	ME	C	1
14	MCQ	ME	C	1
15	MCQ	ME	D	1
16	MCQ	ME	C	1
17	MCQ	ME	C	1
18	MCQ	ME	C	1
19	NAT	ME	3 to 3	1
20	NAT	ME	0 to 0	1
21	NAT	ME	79 to 81	1
22	NAT	ME	49 to 51	1
23	NAT	ME	500 to 500	1
24	NAT	ME	2 to 2	1
25	NAT	ME	1 to 1	1
26	MCQ	ME	C	2
27	MCQ	ME	A	2
28	MCQ	ME	B	2
29	MCQ	ME	D	2
30	MCQ	ME	A	2
31	MCQ	ME	B	2
32	MCQ	ME	D	2
33	MCQ	ME	C	2
34	MCQ	ME	B	2

Q.No.	Type	Section	Key	Marks
35	MCQ	ME	C	2
36	MCQ	ME	C	2
37	NAT	ME	2.4 to 2.6	2
38	NAT	ME	41.00 to 42.00	2
39	NAT	ME	0.78 to 0.80	2
40	NAT	ME	0.16 to 0.18	2
41	NAT	ME	-3 to -3	2
42	NAT	ME	19.00 to 21.00	2
43	NAT	ME	0.48 to 0.52	2
44	NAT	ME	21.90 to 22.20	2
45	NAT	ME	0.6 to 0.6	2
46	NAT	ME	57.00 to 58.00	2
47	NAT	ME	2.05 to 2.15	2
48	NAT	ME	8.00 to 8.20	2
49	NAT	ME	705.00 to 715.00	2
50	NAT	ME	28.80 to 29.00	2
51	NAT	ME	0.7 to 0.7	2
52	NAT	ME	1.24 to 1.26	2
53	NAT	ME	274.00 to 276.00	2
54	NAT	ME	0.72 to 0.76	2
55	NAT	ME	941.00 to 946.00	2